

OIL EXPRESSION AS A FIRST STEP TOWARDS BIODIESEL PRODUCTION:

THE EFFECT OF PROCESSING PARAMETERS ON COCONUT
OIL EXPRESSION EFFICIENCIES



J. J. Mpagalile & B. Clarke



INTRODUCTION

- Production of bio-diesel is gaining popularity.
- This has been necessitated by factors such as:
 - The rising in the price of petroleum products.
 - The inadequate foreign exchange to sustain oil importation
- Hence greater efforts on developing local capacities to obtain bio-diesel for various uses
- Examples of use vegetable oil as bio-diesel
 - Either directly after expression
 - After modifying the oil to attain the required properties.



INTRODUCTION

- However, before oil is obtained and used as bio-diesel, oilseeds must undergo:
 - **Either expression or**
 - **Extraction process** - in order to remove the entrapped oil.
- **Expression** - The process of mechanically pressing liquid out of liquid-containing solids
- **Extraction** - Refers to the process of separating a liquid from a liquid-solid system
- The initial challenge therefore in bio-diesel production is to efficiently express its oil.

INTRODUCTION

- In order to achieve an efficient oil expression,
 - A well-designed system (*efficient oil-press*)
 - Understanding of the oil expression mechanisms and process variables
 - Optimized conditions.
- Some of the important parameters include:
 - Particle size,
 - Pressing time,
 - Pressure,
 - Temperature and
 - Moisture content
- This study was conducted in order to:
 - establish a relationship between oil expression efficiency and the main process parameters using fresh coconut gratings as raw material.

MATERIALS AND METHODS

- The specimens used in this study were prepared using freshly harvested coconuts.
- Fig 1 shows steps for prep of coconuts to obtain coconut oil

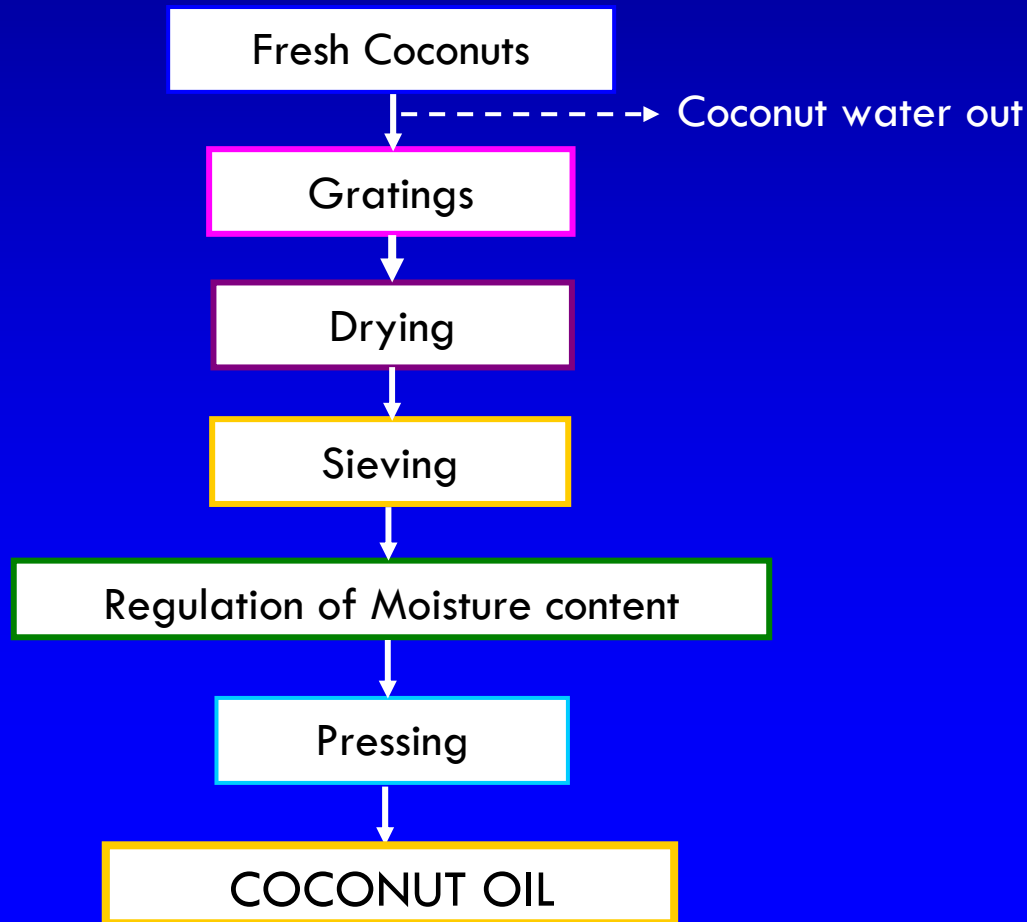

MATERIALS AND METHODS

- A range of variables was investigated under this study.
 - Pressing time (4 and 8 minutes),
 - Particle sizes (Coarse - passing through sieve of 2.36 mm and retained by a 1.18 mm sieve and fine - passing through sieve of 1.18 mm and retained by a 0.6 mm sieve),
 - Pressure (3, 13, 23, and 33MPa),
 - Temperature (30, 60 and 90°C),
 - Moisture content (3, 7, 11 and 15%)
- A piston type test rig (Fig 1) was used in this study
- Avery Universal Test machine type E 63215 (Avery Ltd, UK) was used to provide the required compression forces to operate the rig.

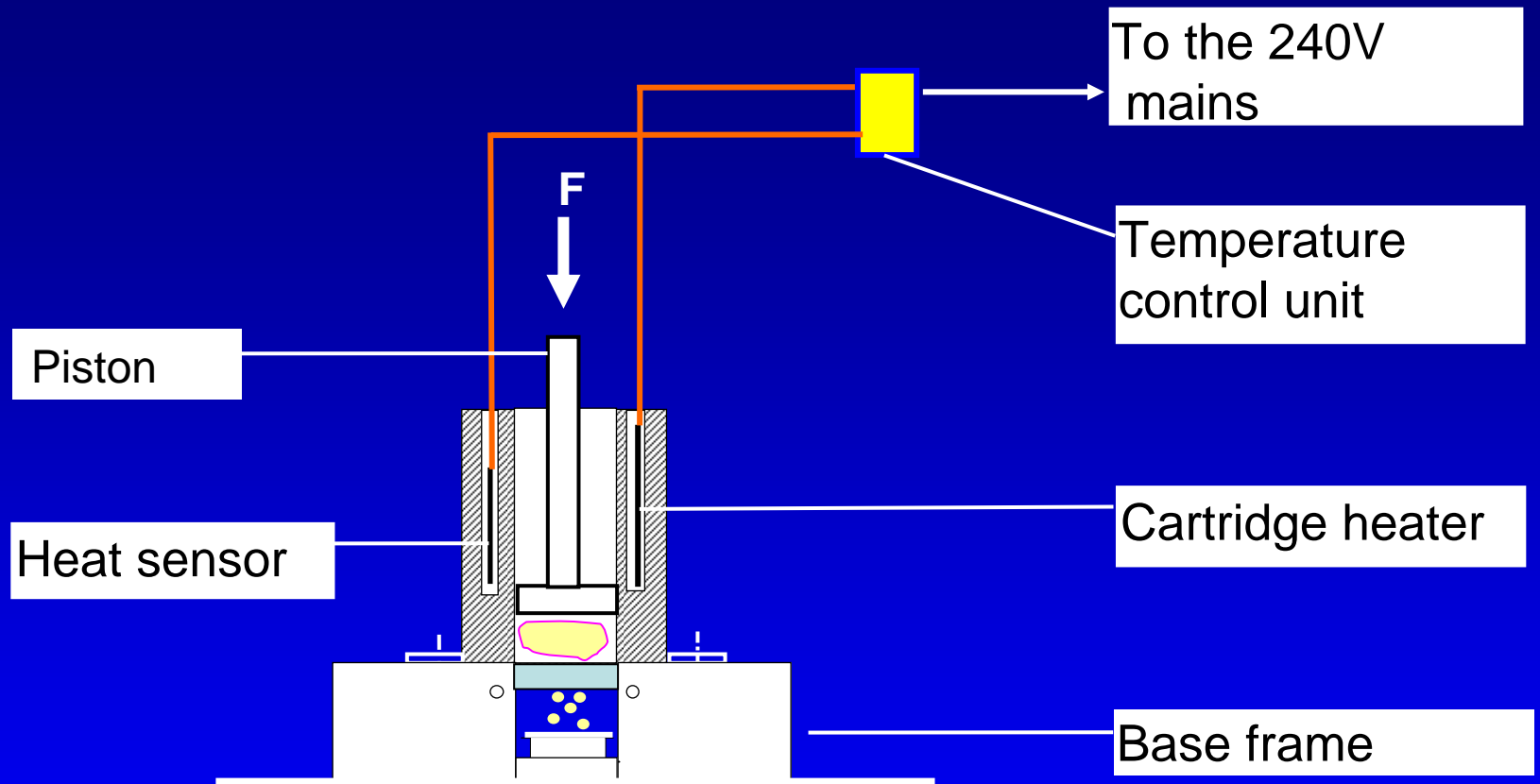

Fig. Piston type test rig

RESULTS AND DISCUSSION

Pressing time under low P pressing:

- As expected 8 min of pressing led to higher OEE
- Slow deformation – Slow compaction of cell matrix led to unrestricted oil flow
- Hence improved OEE

Particle sizes:

- Higher OEE obtained for fine particles
- Shortened distances of oil travel
- Increased surface area exposed to applied P
- Weakened cellular matrix during gratings of fine particles

RESULTS AND DISCUSSION

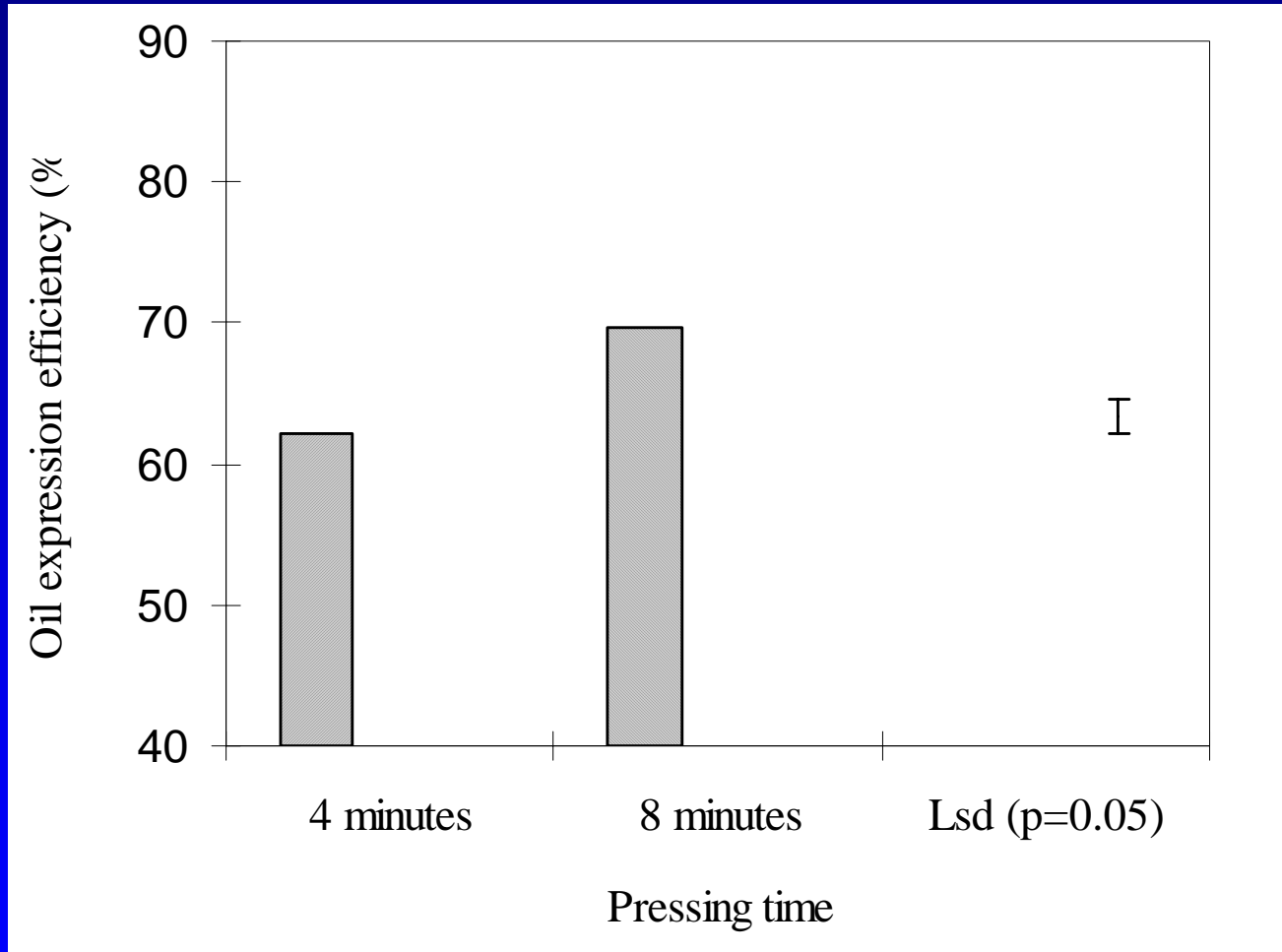

RESULTS AND DISCUSSION

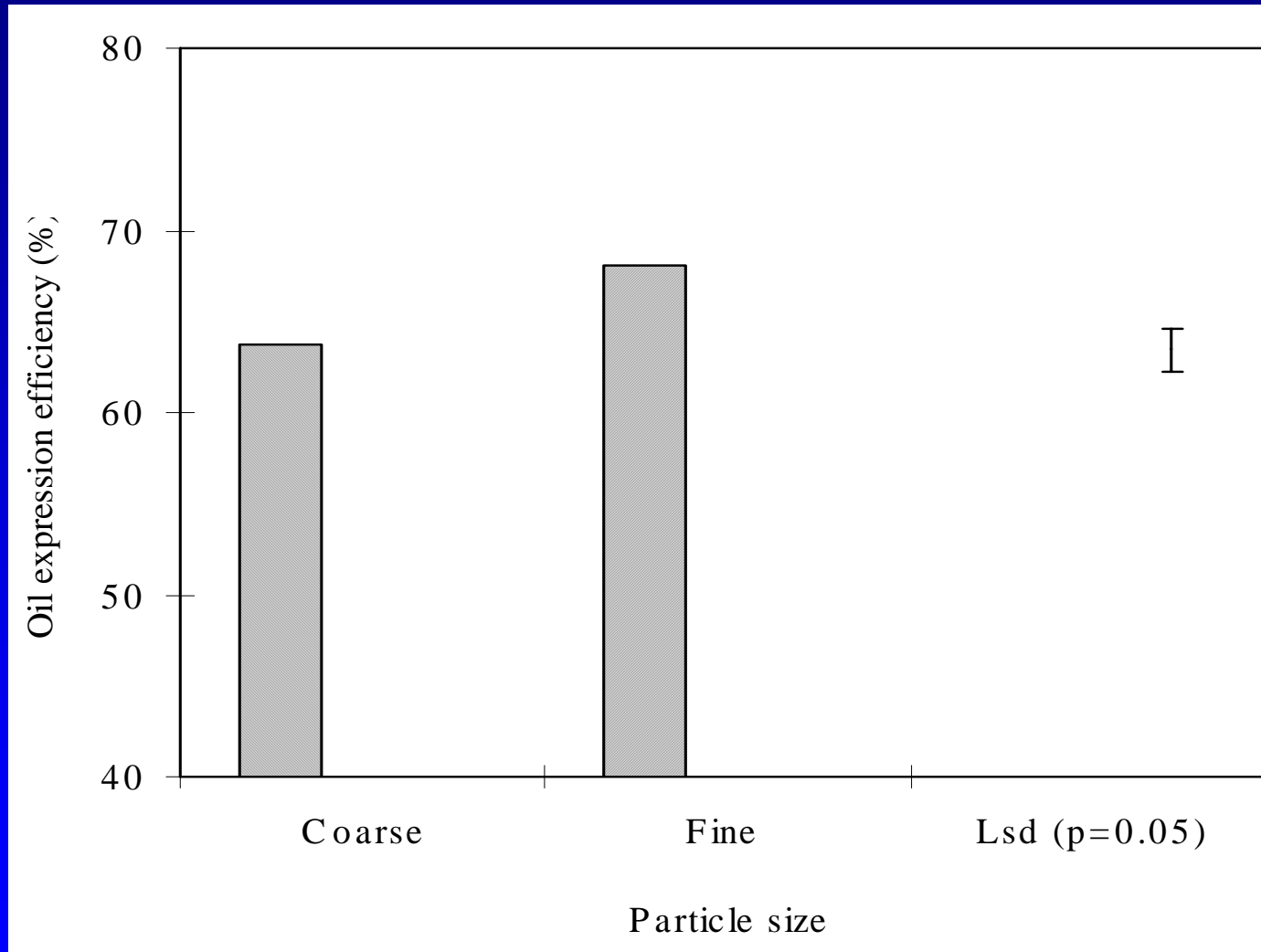

RESULTS AND DISCUSSION

- At low P (3MPa) pressing OEE increase with increase in mc reaching peak at 11%
- Manipulating mc enabled higher OEE at low P
- Thereafter OEE falls if P is maintained
 - Softer materials at 11% mc
 - At this mc oil has little affinity to the hydrophilic surfaces as compared to that of water
 - Water wets the compressed cellular structure replacing oil droplets
 - At around 11% cell rupture was not necessary, but rather oil ooze out through pores soon the cell wall (evidenced by low P)
 - As P is increased cell wall openings are blocked by crushing structure, escape routes are blocked
 - At 3MPa no H₂O expressed oil is free from water

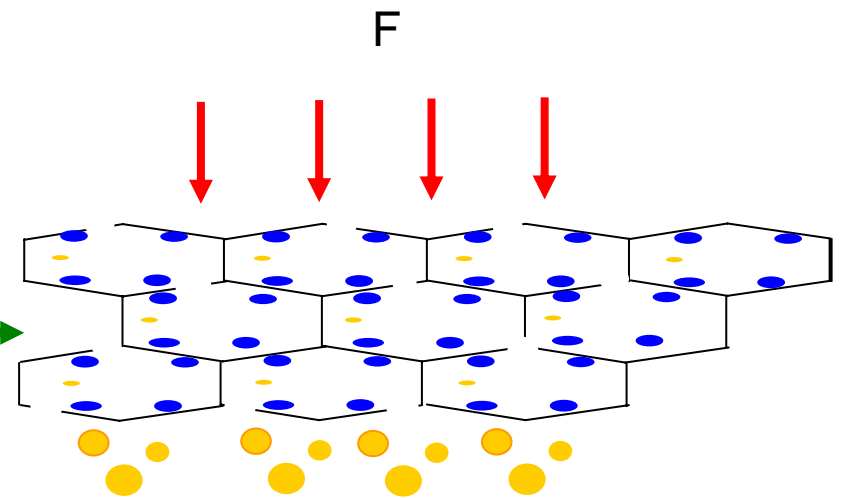
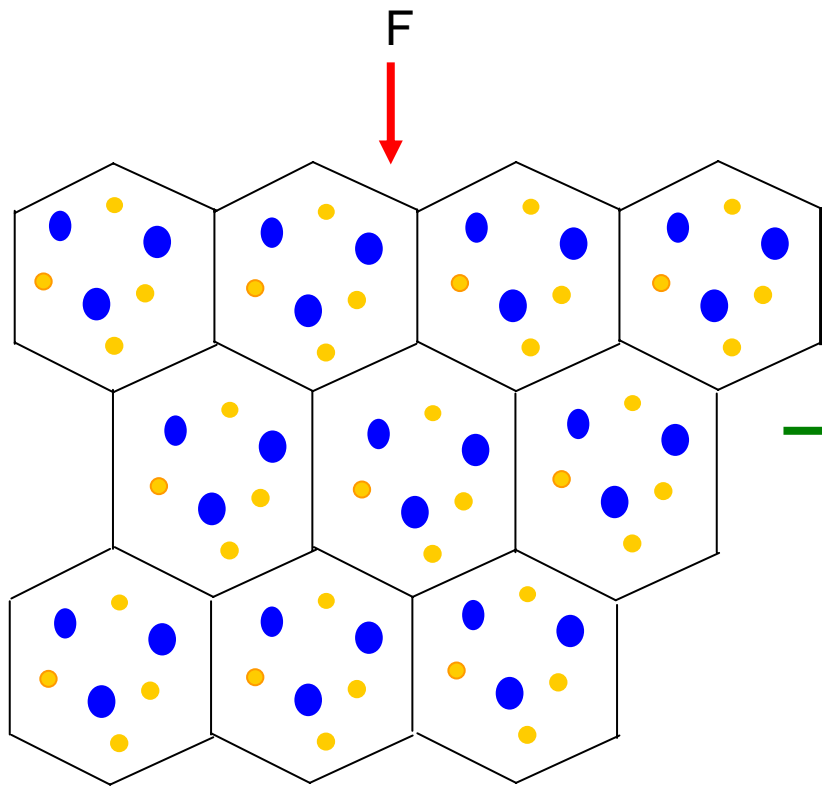

- Water droplets
- Oil droplets

RESULTS AND DISCUSSION

OEE change with change in Moisture content at 3 MPa

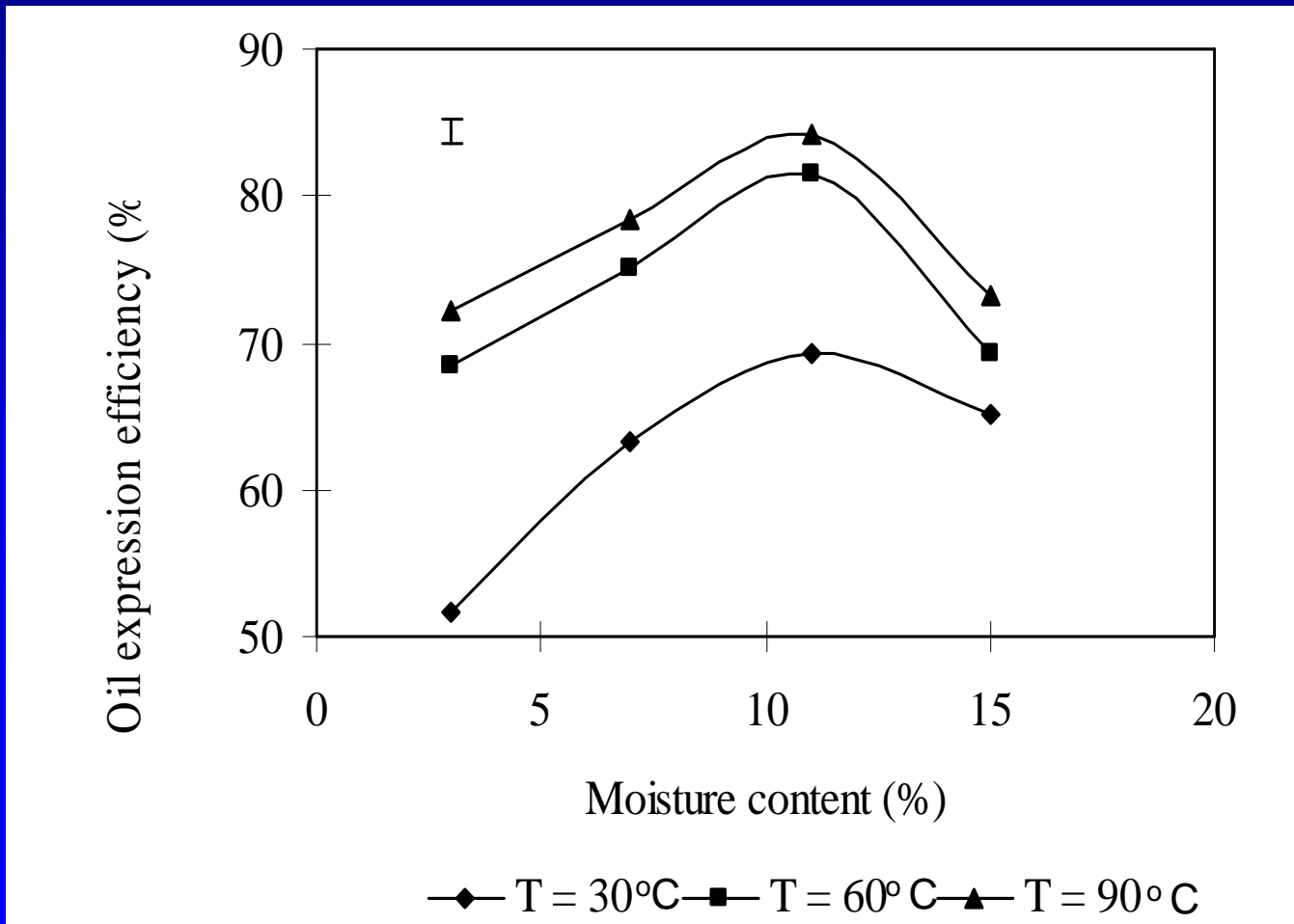

RESULTS AND DISCUSSION

- At higher pressures (13MPa and above)
 - High OEE is registered at low mc i.e. drier materials (3%mc)
 - Drier gratings under high P did not experience high cellular compaction as compared to softer materials
 - Oil droplets flow were not curtailed hence oil being expelled
 - As mc is increased OEE drops at high mc and water droplets starts to appear in oil

RESULTS AND DISCUSSION

OEE change with change in Moisture content at 13 MPa

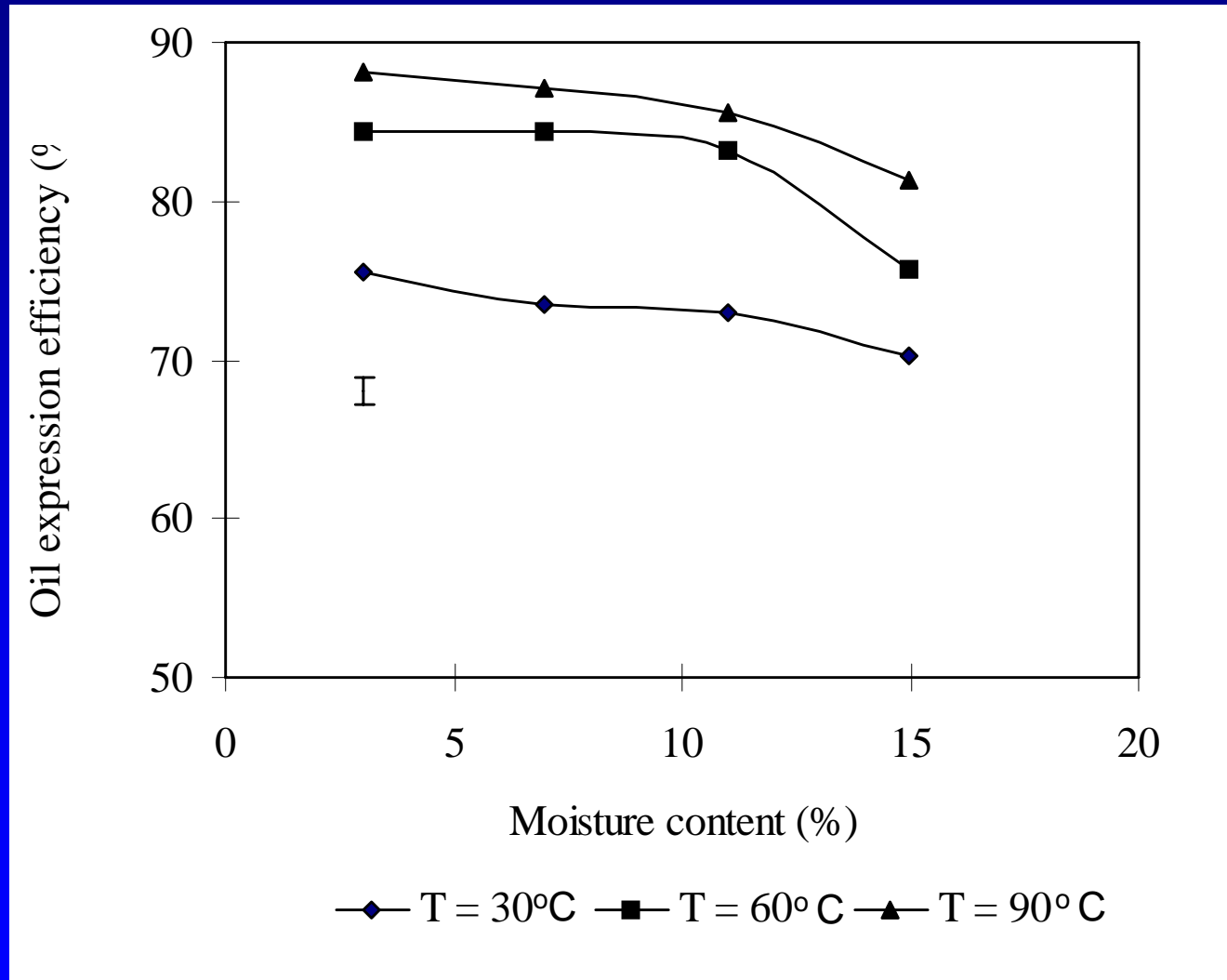

RESULTS AND DISCUSSION

- Temperature effect:
 - Increase in T led to higher OEE
 - Softens tissues i.e. weakens cellular structure
 - Increases viscosity
 - However low effect as T increase from 60 to 90
 - Hence optimize at 60oC couple with low P

CONCLUSION

- Moisture plays a significant role in OEE at low P of about 3MPa
- OEE Peaks at 11% for low pressure pressing
- For drier gratings (3% mc)- OEE increase with increase in pressure
- OEE Levels off at higher pressure
- There is no definite model of oil release from oilseeds BUT:
 - Oil release mechanism is rather influenced by the **PRESSING CONDITIONS** that prevail mainly MC and P
- Using mc of about 11%, T of 60oC, P of 3 MPa coupled with fine particles and about 8 min of pressing may be provide good OEE under small scale oil expression industry

THANK YOU VERY MUCH FOR YOUR
ATTENTION

ASANTE SANA



